

THE INFORMATION CONTAINED HEREIN IS CONFIDENTIAL AND PROPRIETARY TO ALAMARIN-JET OY AND IS NOT TO BE REPRODUCED, MODIFIED OR USED WITHOUT PRIOR PERMISSION OF ALAMARIN-JET OY OR ITS DULY AUTHORIZED REPRESENTATIVE. ALL RIGHTS RESERVED.

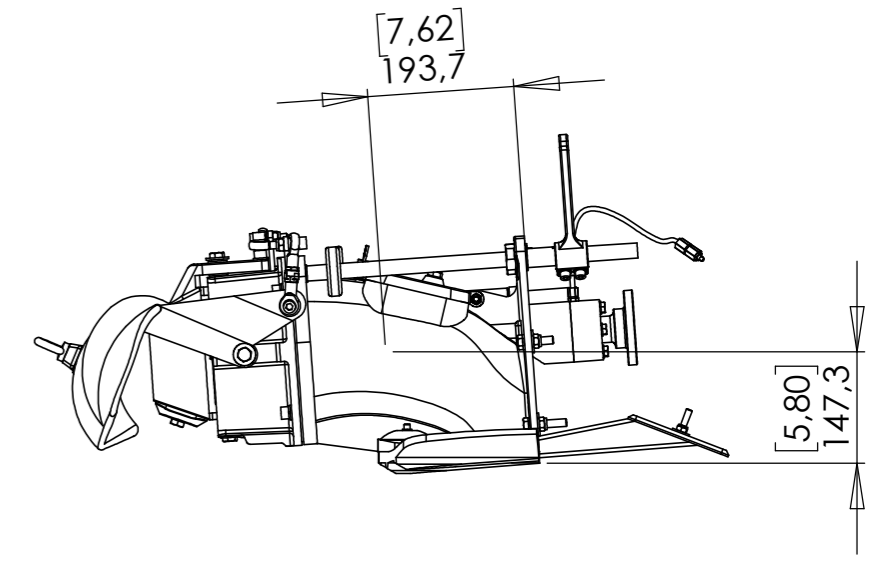
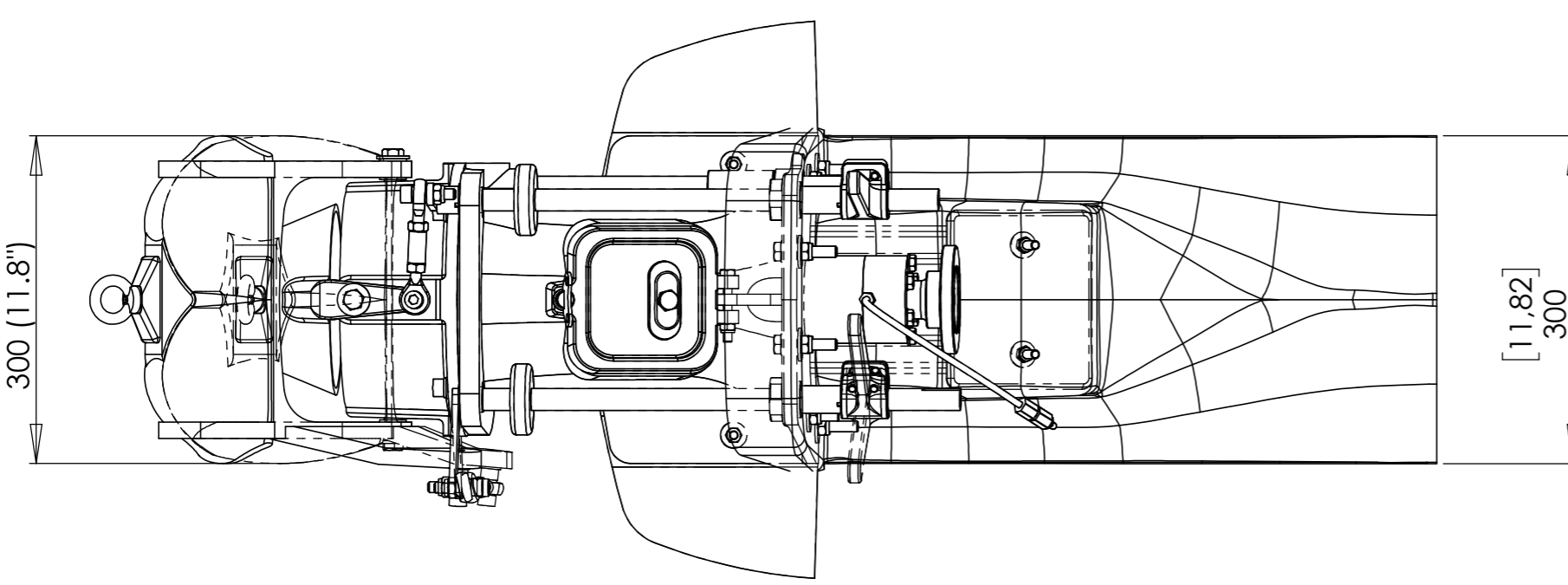
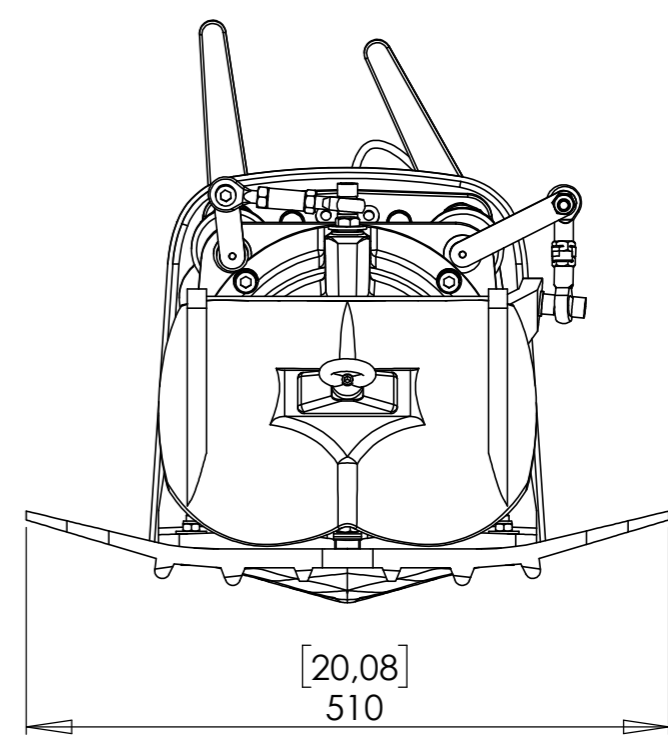
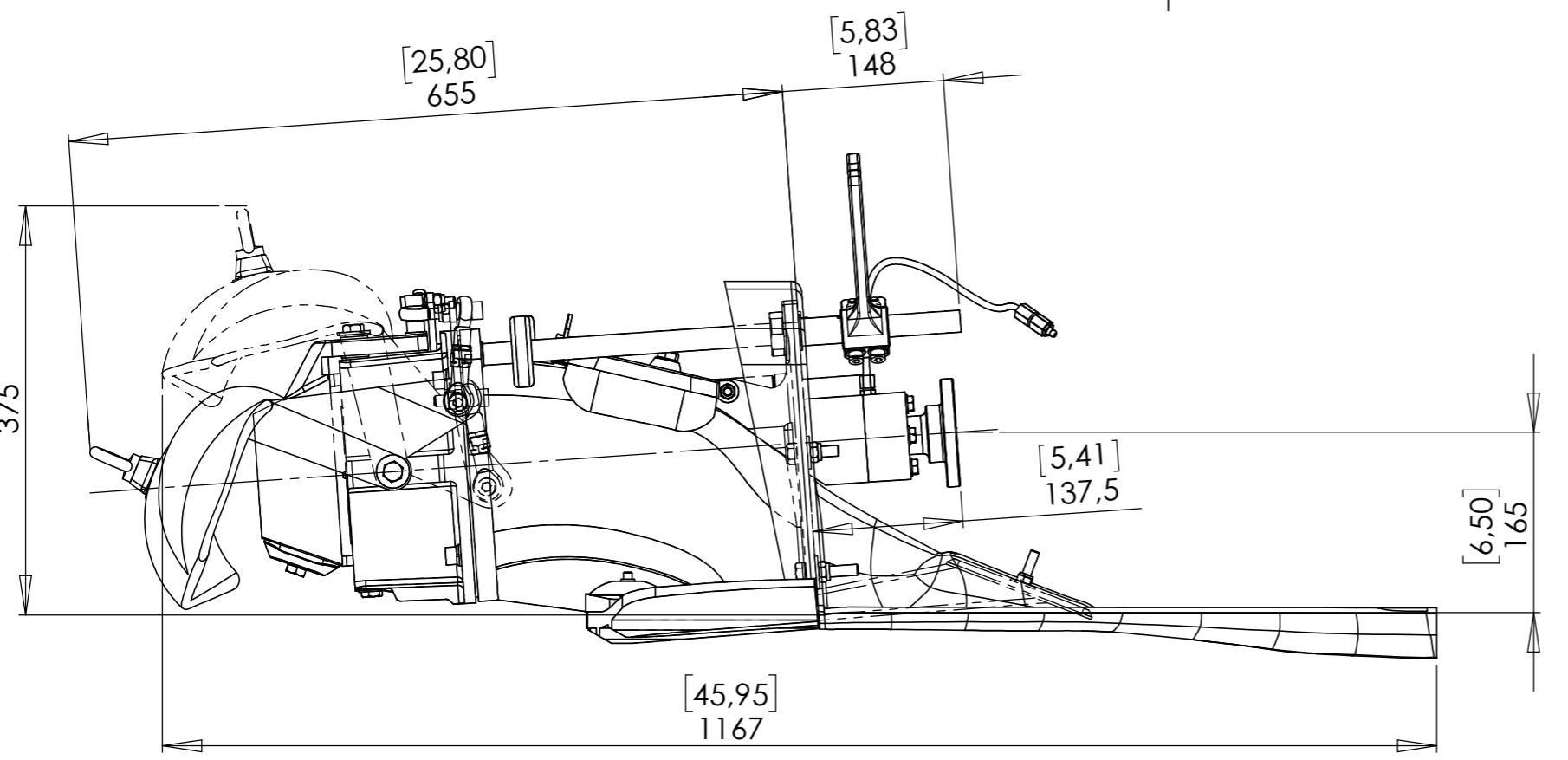

COG without adapter
SCALE 1 : 10

Muutos / Change

Suunnittelija / Designed
Hra 27.01.2021

Hyväksyjä / Approved by

Work Tolerances:
Machining SFS4011 (ISO2768) middle
Welded structures SFS3393-B length and angles
Form and orientation tolerances DIN8570BL3 - E
castings SFS-IS08062

Surface treatment	Surface area [m ²] 3.20	Mass [kg] 39.54	Designer	
Colour		ISO	Approved TOj	1.6.2006
assembly		Product code JET-160	Version B	
Size A3	Scale 1:6	Page 1/4		

